

COMMERCIAL ESCALATORS

Hind Elevators is one of the reputed names engaged in offering commercial escalators. Appropriately designed to suit the specific requirements of the clients, our escalators are made in compliance with the highest quality standards. Widely used in malls, restaurants, metro stations, airports and various other places, our escalators enhance the look of the place and building. These are customized and installed by us, at most competitive price.

Product Features

- ▶ Escalator Suitable for hotels, office buildings, super markets and airports.
- ▶ The step width can be 600mm, 800mm and 1000mm.
- ▶ The inclination can be 30 and 35
- ▶ The alternative function includes VVVF, auto-lubrication & error analysis.
- ▶ The requirements can be customized
- ▶ Automatic inspection status transformation
- ▶ Handrail entrance device
- ▶ Up and down start key
- ▶ Emergency button/operation break control
- ▶ Broken step chain safety device
- ▶ Comb safety device/Protection from over speed
- ▶ Non-reversing safety device
- ▶ Inspection device
- ▶ Overload protection
- ▶ Control device for handrail breakage
- ▶ Phase monitoring relay
- ▶ Auxiliary break [H>6.0m]

S310-35K Commercial Escalator

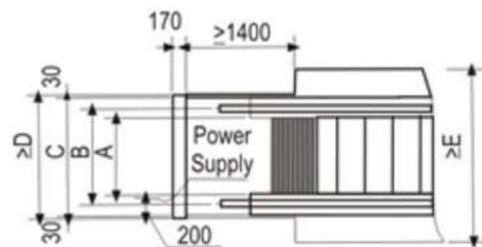

	S301-35K60	S310-35K80	S310-35K100
A	600	800	1000
B	838	1038	1238
C	1200	1400	1600
D	1260	1460	1660
E	1838	2038	2238
F	18500	16900	15700

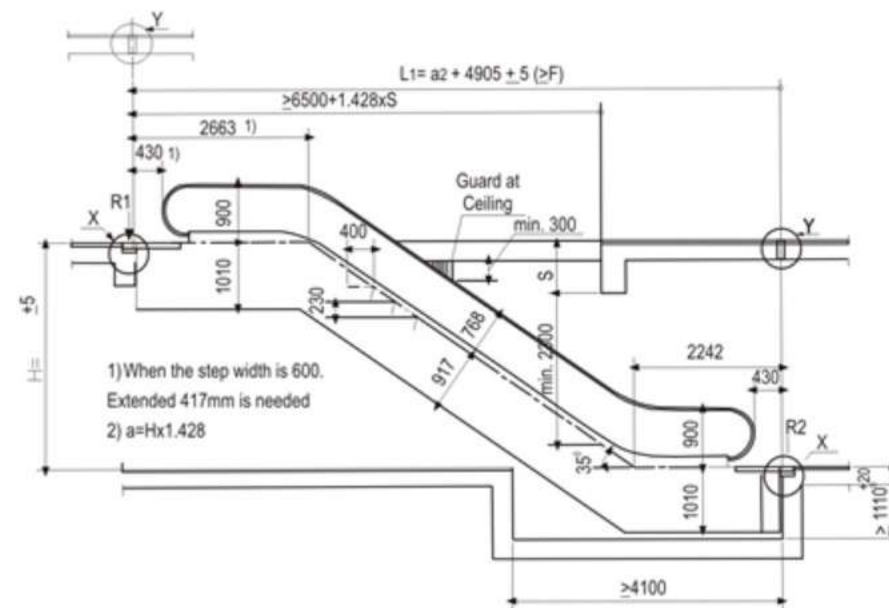
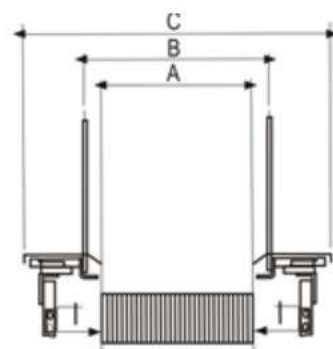

Handrail color (Optional and diversified handrail colors)

